

TQMP2020 / TQMP1020

The move-in of Multicore

The embedded modules TQMP2020 and TQMP1020 build the next generation of the well-known PowerQUICC III module family TQM85xx. The NXP QorIQ™ processor family P1 and P2 opens up the possibility of new applications in industry and communications.

With one or two e500 cores and a clock speed ranging from 400 MHz to 2x1200 MHz, the TQ modules with its QorIQ™ processor offers an optimal balance between data processing speed and power dissipation. Thanks to the 45nm technology employed, power consumption is markedly lower than in comparable PowerQUICC III modules.

This along with the extended temperature range means that it can be fitted to fanless systems. The TQ minimodules TQMP2020 and TQMP1020 are ideally suited to industrial applications where long-term availability, outdoor ambient temperatures and small sizes are important factors.

The highlights:

- Easiest migration of Power QUICC III on QorIQ by approved e500v2 Core
- Single- and MultiCore(s) of 400 up to 1200 MHz in 45nm SOI for best Performance/Watt ratio
- High-Speed communication via 3x Gigabit Ethernet, 3x PCIe and one USB 2.0 interface
- Simple function extension via PCIe, SPI, I²C and flexible local bus
- IEEE 1588 synchronization on time in Hardware
- Extremely compact with only 74 x 54 mm

Block diagram TQMP2020

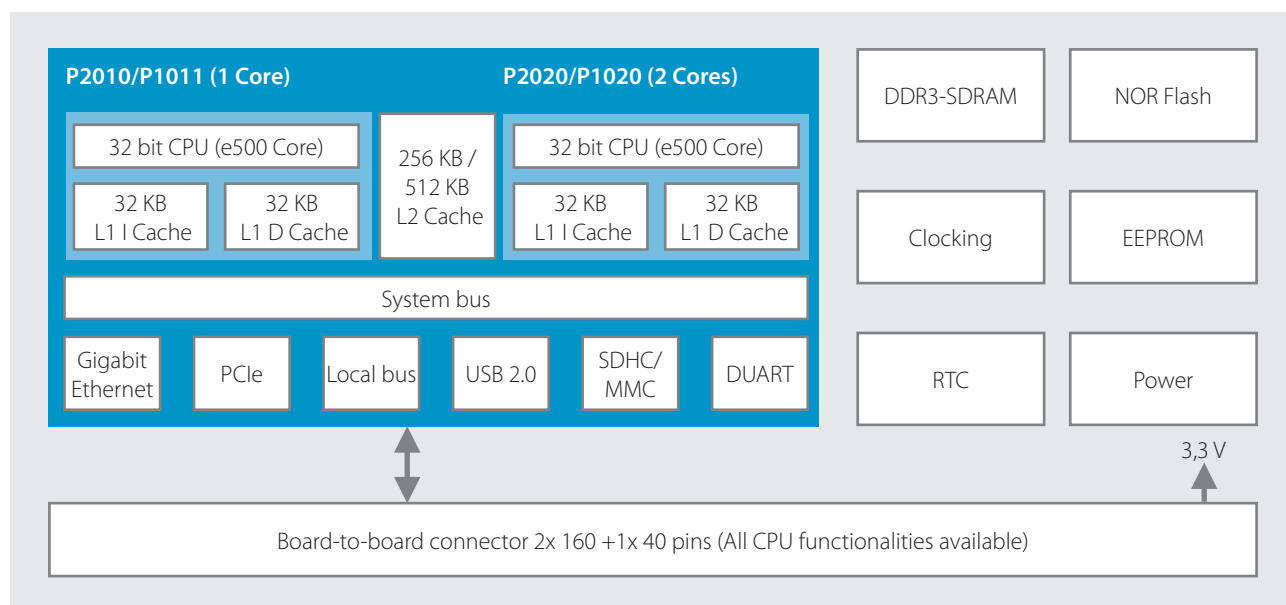

Technical specification

Microprocessor

Dual (P1020/P1021/P2020) or single (P1011/P1012/P2010) high-performance Power Architecture e500v2 Cores

System interfaces

3x Gigabit Ethernet
1 USB 2.0 HOST
3x PCIe (2x), 1.0a Controller up to 2.5 Gbit/s according to PCI Express specification 1.0a as Root-Complex or Endpoint
1x Enhanced Local Bus 16 bit, max. 66 MHz
2x I²C, max. 400 kHz
1x SPI
DUART, max. 115 kBaud (RS232)
Up to 16 GPIOs
2x Serial Rapid I/O (SRIO)
1x TDM

Memory

DDR3-SDRAM: up to 2 GB (higher memory sizes on request)
NOR flash: 128 MB (higher memory sizes on request)
EEPROM: 32 KByte
Simple expansion for example via MMC, SDHC, USB

Other

Real Time Clock (RTC)
Watchdog
JTAG Interface

Power supply

3,3 V

Ambient conditions

Standard temperature range: 0°C...+70°C
Extended temperature range: -40°C...+85°C

Dimensions

74 mm x 54 mm

Plug-in system

Board-to-board plug-in system 360 Pins

Operating systems

Linux, QNX

Operating systems on request

VxWorks and more

Ordering information

TQMP2020-AA

TQ minimodule with P2020 Dual Core CPU with 2x 1000 MHz, 512 MB DDR3 SDRAM, 128 MB NOR flash, 32 KByte EEPROM, -40°C ... +85°C

TQMP2020-AC

TQ minimodule with P2020 Dual Core CPU with 2x 1000 MHz, 2 GB DDR3 SDRAM, 128 MB NOR-Flash, 32 KByte EEPROM, -40°C ... +85°C

TQMP1020-AA

TQ minimodule with P1020 Dual Core CPU with 2x 800 MHz, 1 GB DDR3 SDRAM, 128 MB NOR flash, 32 KByte EEPROM, -40°C ... +85°C

STKP2020-SET / STKP1020-SET

Starter kit with TQ mini module TQMP2020 or TQMP1020, accessories, heat spreader, module extractor and documentation.

Starter kit Baseboard

The baseboard STKP2020 supports all modules of the type series TQMP20xx and TQMP10xx and represents an universal platform for evaluation and development of customer specific platforms for those modules.

Baseboard: Design support | Production

At TQ you not only get first-class embedded systems – we also provide a series of benefits around the embedded module:

- Support in writing a technical specification for gathering the requirements of your application
- Support in selection of components up to Obsolescence management
- Circuit diagram review
- Software, especially Board Support Packages and Hardware-close driver
- Starting-up of your baseboard

As system service provider TQ is able to take over the development, production and test of your baseboard. Therefore you get the whole tested unit from one hand.

TQ-Systems GmbH

Mühlstr. 2 | Gut Delling | 82229 Seefeld | Germany

Phone: +49 8153 9308-0 | Fax: +49 8153 4223

info@tq-group.com | www.tq-group.com

>> Quicklink: www.tq-group.com/en/TQMPxxxx

